Seoul, ready to share with the world!

Seoul Metropolitan Rapid Transit



CONTENTS



06 Seoul Metropolitan Rapid Transit

- 1_ Global Recognition of Seoul Metropolitan Rapid Transit
- 2_ General Overview of Seoul Metropolitan Rapid Transit
- 3_ History of Seoul Metropolitan Rapid Transit

26 Patents, Awards, and Overseas Export

10 Best Practices of Seoul Metropolitan Rapid Transit

- 1_ Fast and Safe urban railway
- 2_ Convenient and pleasant urban railway
- 3_ Cutting-edge technologies and methods of urban railway construction
- 4_ Smart Operation of urban railway
- 5_ Future of Seoul Metropolitan Rapid Transit

28 Q&A

Seoul Metropolitan Rapid Transit is a global leader in urban railway innovation

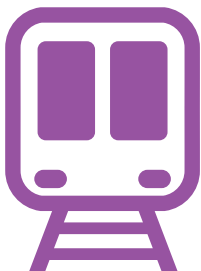

Seoul Metropolitan Rapid Transit,

despite its short 40-year-long history, has grown to become one of the world's largest urban railway networks, boasting world-class travel volume, punctual operation, and safety. It is the only subway system in the world that provides mobile phone services and Wi-Fi services, incorporating information technology and other cutting-edge technologies, in addition to convenient services, it ensures the highest energy efficiency in the world. Seoul Metropolitan Government's commitment and efforts to create a more convenient and pleasant urban railway system has strengthened the competitiveness of Seoul Metropolitan Rapid Transit, which will not settle for the status quo, but challenge itself to continue to develop new technologies and pursue innovation.



Vision

People-Oriented, Convenient Transportation in Seoul

Strategy

1. Fast and safe urban railway
2. Convenient and pleasant urban railway
3. Economical and environment-friendly urban railway construction
4. Smart operation through cutting-edge technologies

Goal

Faster and more convenient railway-oriented efficient public transportation



Seoul Metropolitan Rapid Transit is at the center of people-oriented public transportation that considers the traffic environment, productivity, and growth engines of urban life



Seoul, a city where citizens do not have to rely on cars for convenient living

01 Global Recognition of Seoul Metropolitan Rapid Transit

Awards

'Special Recognition Trophy on Technology Innovation' at the 11th UITP (Union internationale des Transports Publics) Asia-Pacific Assembly in 2011

'The Best Technology and Innovation Award' at the 59th UITP World Congress in 2011

- ▶ StnF system
- ▶ Tunnel monitoring system

'Best Metro Asia Pacific' and **'Most Energy Efficient Metro'** at Metro Rail in 2011

'Best Organization for Efficient Transportation' at Metro Rail in 2009

Press releases worldwide

Seoul



Operated by three different companies (two of them state-funded), the Seoul metro system carries almost 7 million passengers per day on nine lines.

In addition to being one of the only metro systems in the world with cell phone service and Wi-Fi, many of the Seoul subway trains are outfitted with TVs and are climate controlled. We love the toasty, heated seats in the winter.

PARK JI-HWAN/GETTY IMAGES

The world's first virtual mall for smartphone users opened at Seoultung Station in Seoul in 2011.

"Many subway planners come to Korea and are really blown away by the technology that we have in place," says Jung-whan Kim from Seoul Metro's media team. "It's a big showpiece for Korea's emphasis on IT."

The only downside is the early closing time -- around midnight on weekdays, a little earlier on weekends -- considering how obsessed the city is with nightlife.



The source : <http://jalopnik.com/5958482/the-best-subway-systems-in-the-world>

Seoul Metropolitan Rapid Transit was ranked #1 Best Subway System by Jalopnik.

Tokyo, Paris, Hong Kong was ranked #2, #3, and #4 respectively.

02 General Overview of Seoul Metropolitan Rapid Transit

SMRT is one of the world's heaviest carriers serving a huge number of passengers

Seoul Metropolitan Rapid Transit was created to relieve traffic congestion and reduce air pollution, problems caused an enormous increase of cars and buses due to rapid urban development. Today, it has become the main means of transportation for 20 million people, including Seoul citizens and Seoul metropolitan area residents. Despite its short 40-year-long history, the Seoul Metropolitan Rapid Transit has grown to become one of the world's largest urban railway networks, with 9 lines extending 327 km (including 290 km underground). The average number of passengers per day is 7.2 million and per year is 2.6 billion.

Line map

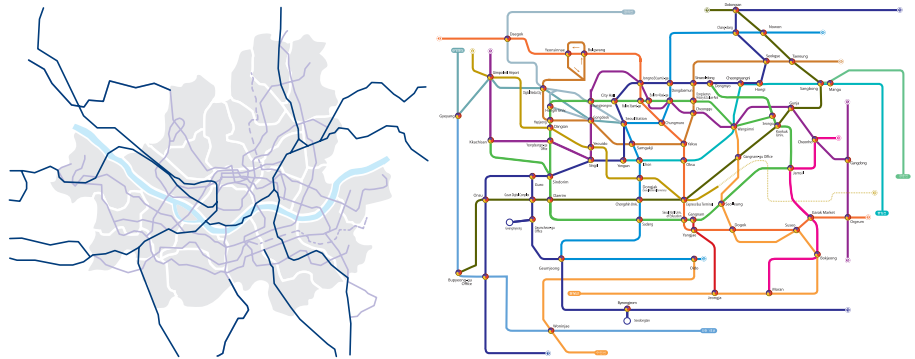

Basic information

9 lines extending 327.1 km, 7.2 million passengers per day, 2.6 billion passengers per year

	No. of lines	Total length	No. of stations	No. of passengers	Operators
Total	9	327.1km	302	7.2 million/day	
Line 1 	4	137.9km	120	4.18 million/day	Seoul Metro
Line 2 					
Line 3 					
Line 4 					
Line 5 	4	162.2km	157	2.64 million/day	Seoul Metropolitan Rapid Transit Corporation
Line 6 					
Line 7 					
Line 8 					
Line 9 	1	27km	25	0.38 million/day	Seoul Metro 9 (private corporation)

03 History of Seoul Metropolitan Rapid Transit

Seoul Metropolitan Rapid Transit, created to relieve traffic congestion caused by rapid urban growth, has continued to develop over the years, and today has become one of the best urban railway systems in the world.



Before the 1970's

Era of streetcars

1899. 5
Opened the streetcar service

1968. 11
Stopped (abolished) the streetcar service

1970's

Introductory stage of subway

1970. 6
Established the Seoul Metropolitan Government Office of Subway Construction

1971. 4
Started the construction of line 1

1974. 8
Opened the service of line 1

1978. 3
Started the construction of line 2

1980's

Growth phase of subway

1980. 2
Started the construction of line 3 and 4

1981. 9
Established Seoul Metropolitan Subway Corp. (currently referred to as Seoul Metro)

1984. 5
Opened the service of line 2

1985. 10
Opened the service of line 3 and 4



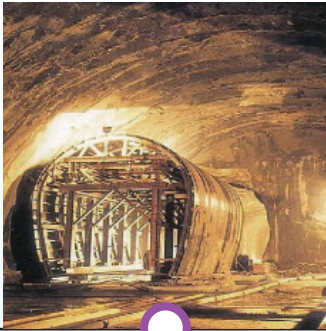

1990's

Development phase of subway

- 1990. 6
Started the construction of line 5
- 1990. 12
Started the construction of line 7 and 8
- 1994. 1
Started the construction of line 6
- 1994. 3
Established Seoul Metropolitan Transit Corp.
- 1996. 12
Opened the service of line 5
- 1999. 7
Opened the service of line 8



2000's

Maturity/Stabilization period of subway

- 2000. 8
Opened the service of line 7
- 2001. 12
Opened the service of line 6
- 2002. 4
Started the construction of line 9
- 2004. 7
Introduced new transportation card system
- 2005. 2
Started the construction of an extension to line 7
- 2009. 7
Opened the service of line 9 (1st stage)
- 2009. 9
Started the construction of light-rail transit between Ui and Sinseol
- 2012. 10
Opened the service of line 7
- 2012. 12
Currently constructing line 9 (2nd and 3rd stage) / light-rail transit between Ui and Sinseol



Seoul, ready to share with the world

Seoul Metropolitan Rapid Transit

Best Practices of Seoul Metropolitan Rapid Transit

Seoul Metropolitan Rapid Transit is known for punctual operation and passenger safety thanks to application of various cutting-edge technologies. It boasts the lowest accident rate in the world



01 Fast and safe urban railway

Punctual operation

Seoul Metropolitan Rapid Transit's accurate prediction of arrival system ensures punctual operation, enabling citizens to manage their schedules better.

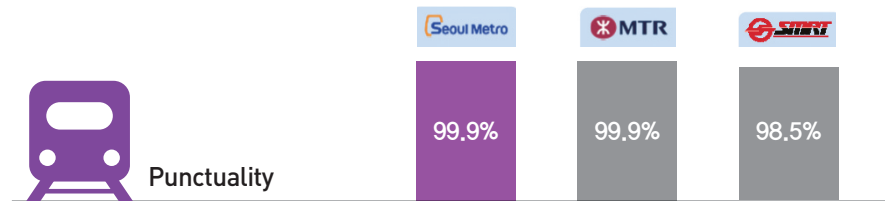

※Punctuality refers to the chance (%) of a train arriving at a station at the exact time (delay within 5 minutes)

Dual operation of ordinary and express trains

The dual operation of ordinary trains and express trains on the same track enables busy citizens to arrive at their destinations earlier than anticipated.



Adopted technology

Automated operation and protection systems automatically sense and control the acceleration and brakes of the train to ensure fast and safe travel.

Effect of application

The operation of the express train from Gimpo Airport Station to Simnonhyeon Station reduced passenger travel time from 54 minutes to 30 minutes.

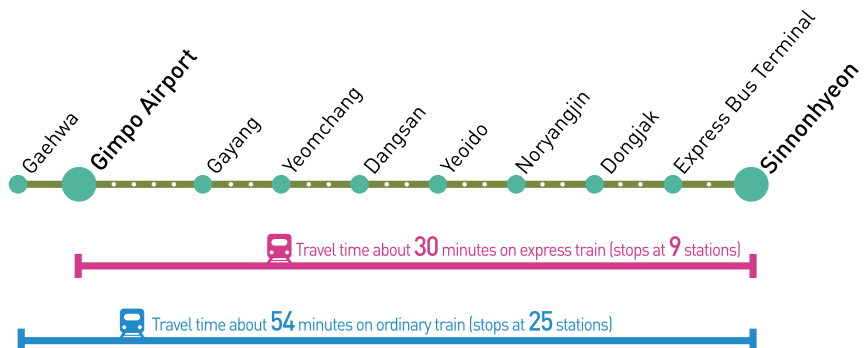

Platform Screen Doors (PSD) for safety

Platform Screen Doors (PSD) were installed in 2006 to prevent passenger accidents and improve air quality. It took 3 years to develop oil-free screw driving systems and module installation methods and to install platform screen doors in nearly all stations.

Effect of application

The installation of platform screen doors are preventing suicide and falling accidents and reducing train draft and noise, ensuring passenger safety and air quality. Also, it is improving heating, ventilating, and air conditioning in stations, raising energy efficiency.

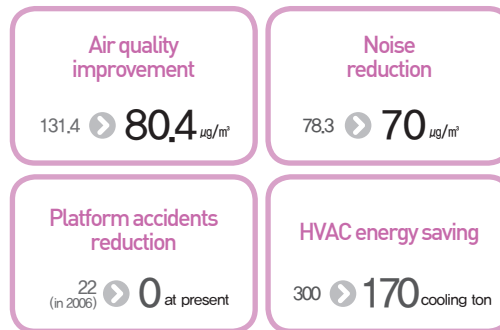

Wireless transmission of image data for real-time monitoring and quick response to safety accidents

The wireless transmission of image data enables real-time monitoring and quick response to safety accidents inside and outside the train as well as on the platforms.

Adopted technology

The two-way wireless transmission using a frequency of 18GHz allows smooth sending and receiving of image data regardless of the train's poor transmission environment.

Effect of application

The driver and engineer of the train can monitor in real-time the situation on the platform, so that they can quickly respond to accidents. Also, the control room and the engineer of the train can monitor the situation inside the train so that they can quickly respond to emergencies such as fire or crime inside the train.

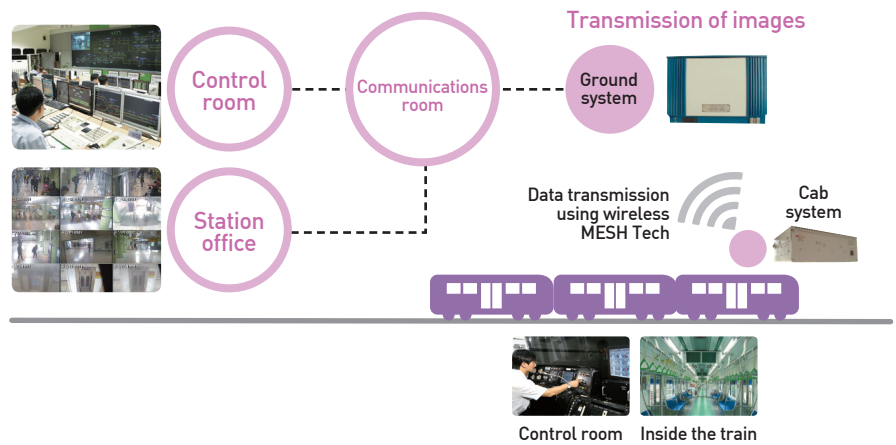

Disaster prevention system

A comprehensive disaster prevention system, including nonflammable materials, Weather Management Certification (WMC), and Multilateral Communication Network (MCN), ensures the safety of passengers against emergencies such as fire accidents or flooding.

Nonflammable materials

Using nonflammable materials for all parts of the train and installing emergency interphones and fire detecting devices inside the train since 2004 ensures passenger safety.



Weather Management Certification (WMC)

Weather Management Certification (WMC) and installation of water blocking panels and CCTVs at the entrance of stations helps monitor the weather situation outside and respond to potential flooding.

Multilateral Communication Network (MCN)

Multilateral Communication Network (MCN) enables swift response to emergencies. Also, subway safety guardians and safety experience programs for citizens help prevent accidents in advance.

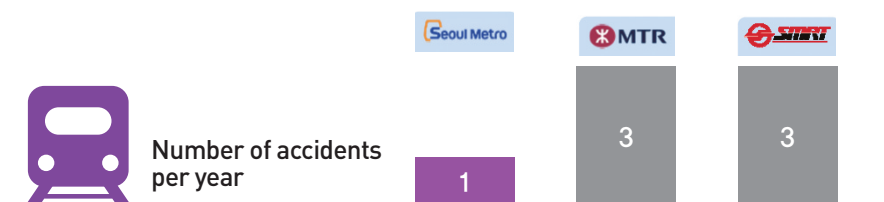

02 *Convenient and pleasant urban railway*

Seoul Metropolitan Rapid Transit offers convenient and pleasant traffic environment through high-end IT solutions.

All-in-one fare system

The all-in-one fare system and transportation card system enables citizens to transfer between urban railway and bus more conveniently.

All-in-one fare system

Under the all-in-one system, passengers are charged with only a basic fare on their transportation card if traveling a 10km distance (transfer between different means of transportation is free of charge). If they are traveling more than 10km distance, they are charged with an additional fare of 100 won per every 5km on their transportation card.

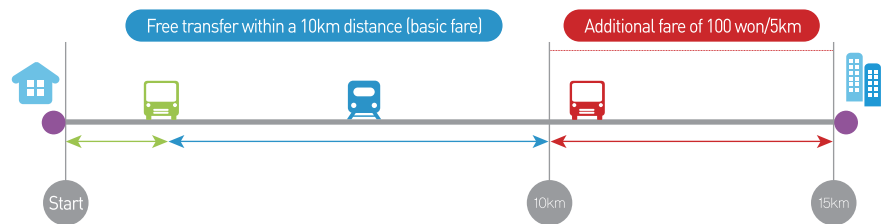

Wireless communication network, free access to Internet

Cutting-edge information technology allows passengers to enjoy wireless Internet and radio and DMB services inside the train.

Effect of application

Multimedia information system provides passengers with useful information such as subway lines, tourist attractions, and living information.



Multimedia information system



Free access to Internet

Real-time subway information

The Bus Information Terminal (BIT) installed inside the stations provide subway information to passengers in real-time. Open API also allows such information to be provided to citizens via Internet and smart phone applications. In particular, a smartphone app called "Seoul Public Transport" was developed to provide real-time information about train operation.

Seoul Public Transport Smartphone App Free mobile app developed by Seoul Metropolitan Government

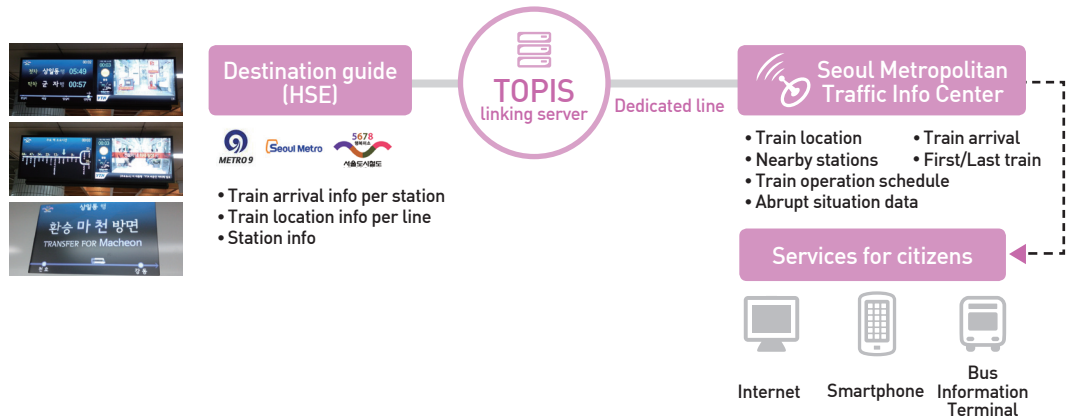

Clean and pleasant stations and trains

Various efforts have been made to improve air quality in stations and trains. For example, installing platform screen doors in all stations, developing new concept cleaning equipment, strengthening maintenance of tunnels and underground stations, and installing automated temperature control device and HAVC system.

Effect of application

The amount of fine dust dropped from 107.6 $\mu\text{g}/\text{m}^3$ in 2007 to 74.3 $\mu\text{g}/\text{m}^3$ in 2011. A CO2 emissions reduction device was developed to create a more pleasant environment in stations.

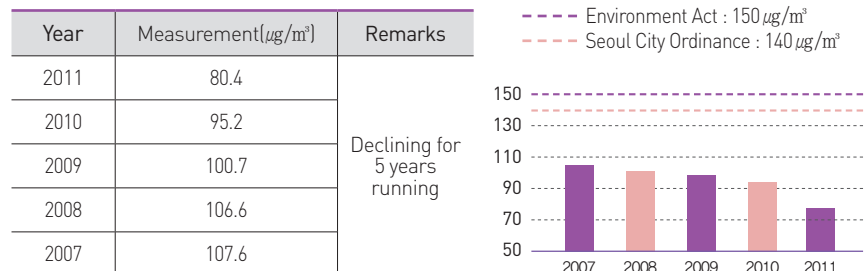

New concept cleaning equipment to improve air quality in stations



High-pressure sprinkler truck

Non-power iron powder train

Water screen truck

Easy accessibility to subway

Subway entrances that were integrated into surrounding buildings were created, and they were simplified as well to improve aesthetics of urban landscape and convenience of mobility. Also, connection of urban railway network, which accounts for a large part of transportation share, to public bus network, and creation of transfer hubs are increasing operational efficiency.

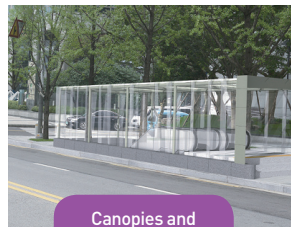

Canopies and escalators

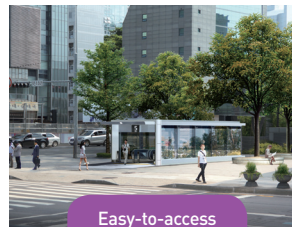

Easy-to-access subway stations



Subway transfer hubs

Facilities for the disabled

Various facilities are being expanded for the disabled to minimize their inconvenience in using public transportation.

Facilities for the disabled

Currently, there are 856 elevators in 292 stations. The goal is to install at least 3 elevators in each of the 302 stations by 2017.

Details of the facilities

- ▶ Braille, blocks to guide the disabled, and other information signs
- ▶ Elevators, wheelchair lifts, escalators, and horizontal auto sidewalks
- ▶ Special space inside trains for wheelchair users, parents with strollers, and passengers with large luggage bags
- ▶ Long handles inside compartments for short passengers to grab on to
- ▶ Hygienic and pleasant rooms for mothers to breast-feed their infants
- ▶ Toilet rooms customized for young children



Culture and arts arena

Seoul Metropolitan Rapid Transit is more than just a means of public transportation. It can also be a public arena for culture and arts, enriching the quality of life of the citizens.

- ▶ Small performance stages and exhibition space
- ▶ Meeting plaza for pleasant and comfortable relaxation
- ▶ Space for working, reading, and leisure (providing Internet access)
- ▶ Small museums and cinemas

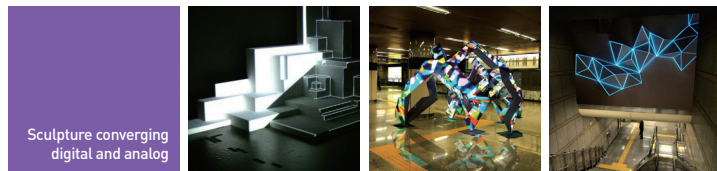
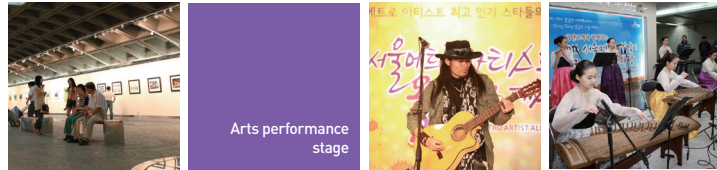

- 1 Advertisement on platform wall
- 2 Ubiquitous space
- 3 Information booths on walls



이동차 발차 4:15
이동차 발차 10:15

첫차 발차 05:51
막차 발차 00:44

↑ ↓

↑
2,4 Line
간이역
Transfer

03 *Cutting-edge technologies and methods of urban railway construction*

To overcome the geographic drawbacks of Seoul, which has a number of hills and mountains and sits along the wide Han River, the city has adopted a series of high-end construction technologies.

Economical and environment-friendly construction methods

Various digging methods were applied to ensure safety, economic efficiency, and construction feasibility. Six railway bridges and two underwater tunnels crossing the Han River were built. Also, Shield Tunnel Boring Machine Method, which is very economical, has minimal impact on ground traffic, and generates little construction pollution, was applied in the urban railway sections of line 9 and 7, for large-scale digging and earth tunnel construction.

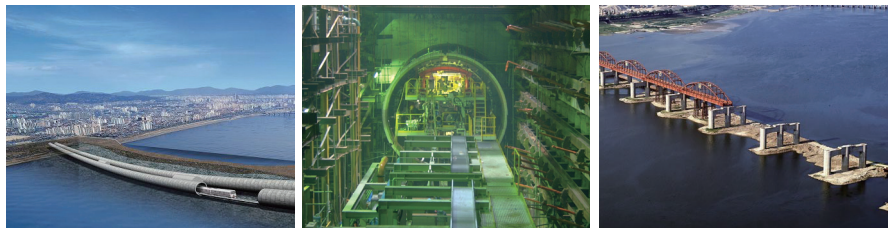

Repair of aged tracks using innovative method

An innovative B2S (Ballasted Track to Slab Track) Method was applied to renovate the existed ballasted tracks to concrete slab tracks.

B2S (Ballasted Track to Slab Track) Method

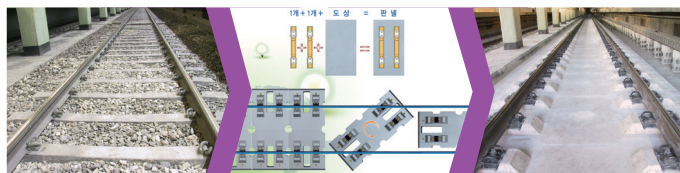

- ▶ Reduction of construction cost : by 500 million won (traditional method 2.4 billion → B2S method 1.9 billion won)
- ▶ Increase of construction efficiency : 7~10m/day → 12~15m/day
- ▶ Environment-friendly construction : noise/vibration 14dB, decrease of concrete use by 25%
- ▶ High quality : no cracks on the road surface, outstanding performance
- ▶ Minimal complaints from residents due to excellent anti-noise, anti-vibration performance

- Economic efficiency comparison (per km): B2S (860 million won) < US LVT (910 million won) < France STEDEF (920 billion won)
- Patents: registered Korean patents (in 2006) for technologies developed in 2002 and foreign patents in EU and Germany (in 2007)

04 Smart operation of urban railway

Seoul Metropolitan Rapid Transit boasts of economical, efficient, and safe operation implemented by a command center, a cluster of cutting-edge technologies designed to ensure safe and convenient railway service.

Automated control system

An automated control system to accurately and quickly transmit voice and image data about train operation information, station management, facilities and equipment regarding stations, communications, AFC, signals, substations, and disaster prevention.

Auto Train Stop (ATS) and Auto Train Operate (ATO) system

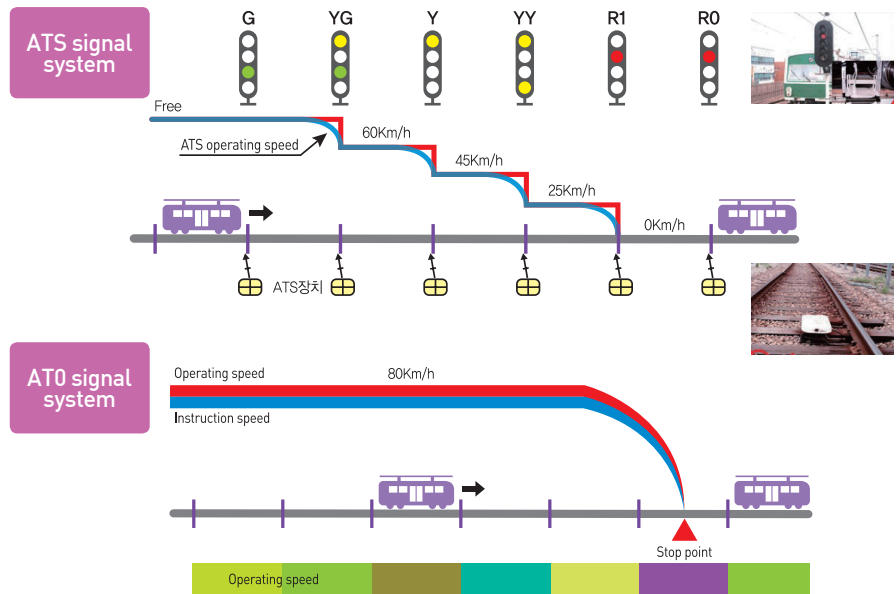

Remote control (SCADA) monitoring system

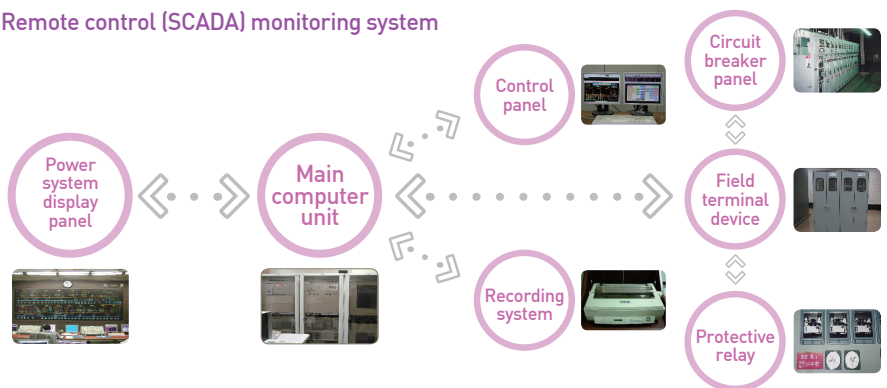

Control system

Signal system for safe train operation, center control room for comprehensive management, monitoring system for train operation, electrical equipment, convenient facilities in station, and safety facilities.

New control system

A task force team was created to develop technologies to update the obsolete control system, plan a broadband, consolidated network, and redesign the overall layout of the master control center, and utilize existing infrastructure. A total of 15 billion won was saved.

Effect of application

Video control, digital data display, minimized space and workforce through integrated operation of line 5 to 8, train, passenger, communications, signals, facilities management function, etc.

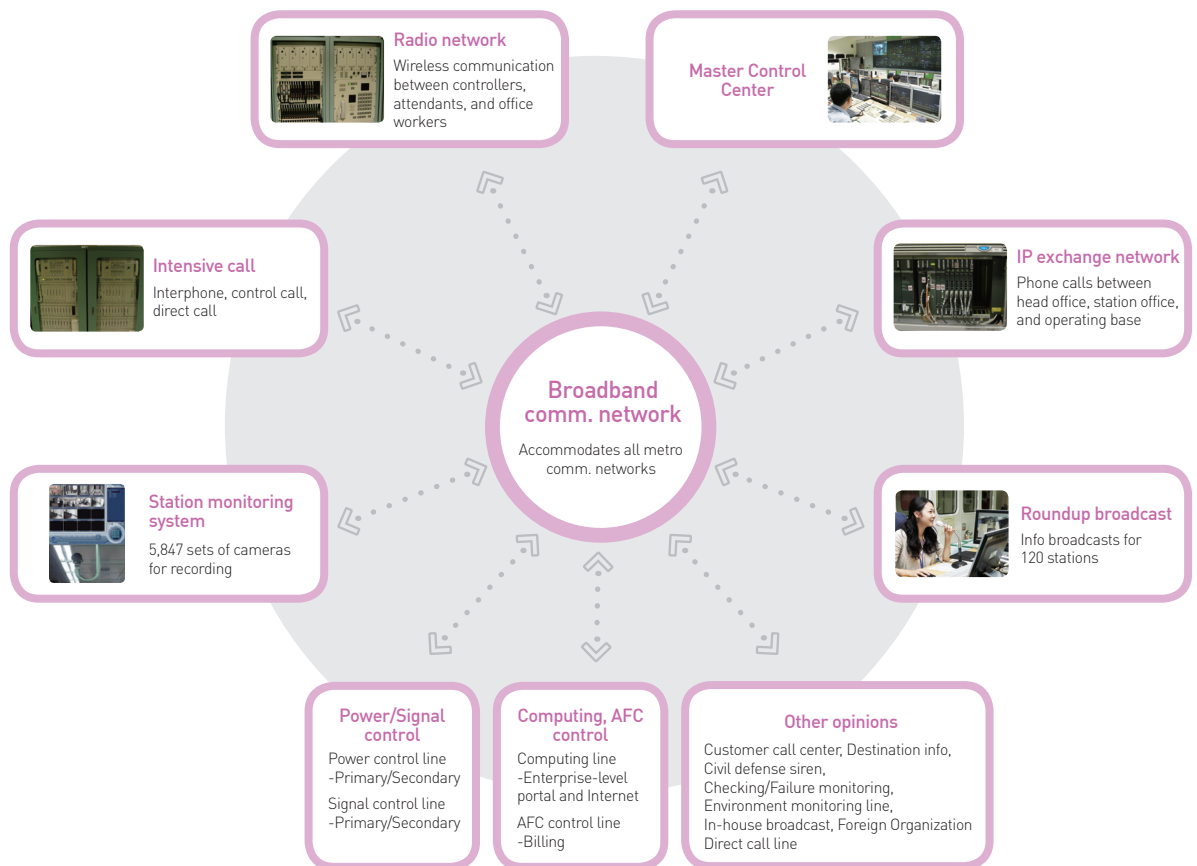

Master Control System (MCS)

MCS offers thorough monitoring and control service across all areas including power, signals, equipment, and communications, from the train's exit to entry from/into the departure line. MCS consists of train/signal control for the safe operation of trains, power control for stabilized supply of power, communications control for the management of neuro-system networks, equipment control for the management of station facilities, and locomotive control for quick response to failure in trains; each control system is implemented with state-of-the-art, zero-defect tech solutions.



Master Video System (MVS)

Installed inside a station, a locomotive, or an entrance to a tunnel, MVS enables identifying all situations at the same time from the control center to ensure prompt actions and preventive measures.

Real-time monitoring system

Real-time monitoring system is designed to identify all the current conditions around the station. It enables efficient response to a situation through real-time monitoring, advance recognition of failure signs, and other analyses. The system consists of CCTVs and noise/vibration/temperature sensors that make for a scientific analysis environment wherein the monitor can check each condition with visual, auditory, and tactile senses. It allows checking every aspect of the station at one spot as well as advance observation of failure signs through sensors and data.

24-hour Tunnel Monitoring System

TMS monitors the inside of tunnels through high-speed infrared cameras mounted on the train. Going beyond the manual monitoring wherein railway workers walk into tunnels to check the conditions, the system offers more scientific monitoring solutions. Compared with the traditional solution, which allows only 4 hours for checking cracks, leak, abrasion of tracks, irregularities in lanes, noise, and vibration, the system enables 24-hour monitoring in addition to analysis of video



▶ Front part of a train used for the Tunnel Monitoring System; mounted on the bottom are Cameras and infrared lighting are installed on the front part of the train to monitor the dark tunnels.

Installed Cameras & Sensors

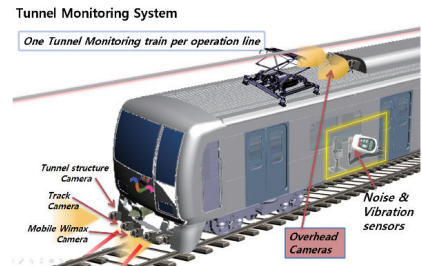
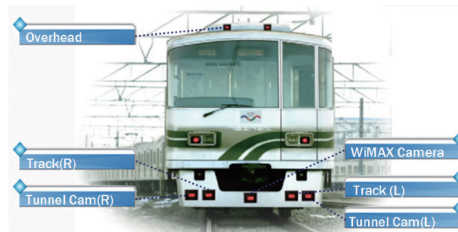

ISO 9001, ISO 14001-certified for all operations

Seoul Metropolitan Rapid Transit Corp. has proven its unparalleled service with the international certifications it acquired and management of urban railway systems for its entire operations, including ISO 9001 (Quality)/ISO 14001 (Environment).



05 Future of Seoul Metropolitan Rapid Transit

Seoul Metropolitan Rapid Transit will not settle for the status quo. It will continue to develop new technologies and pursue innovation.

Policy vision and mission

Vision Railway-oriented public transportation

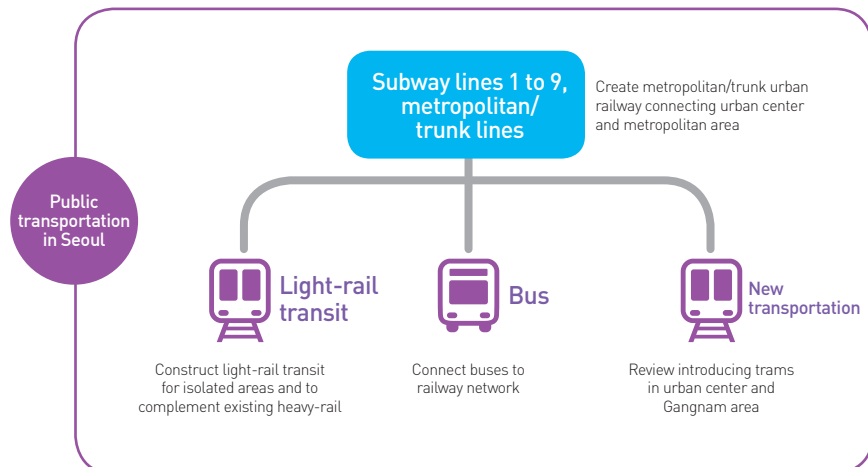
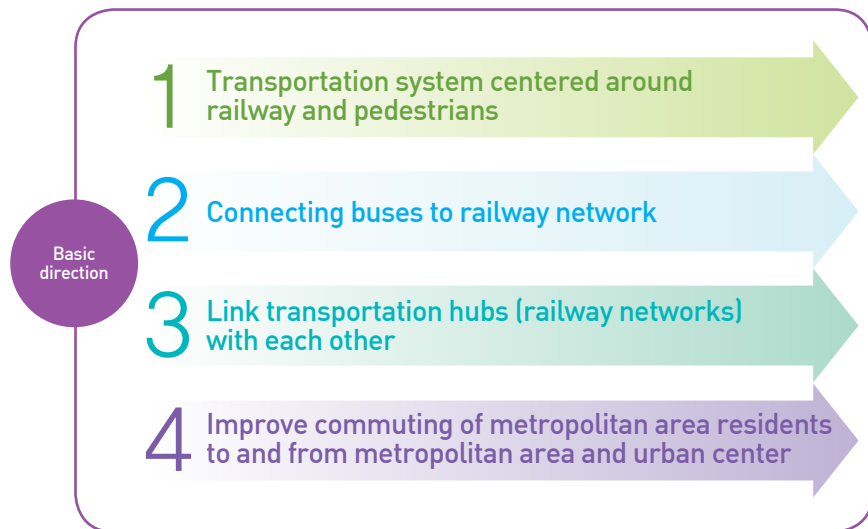

Future urban railway network in Seoul



Future of Seoul Metropolitan Rapid Transit

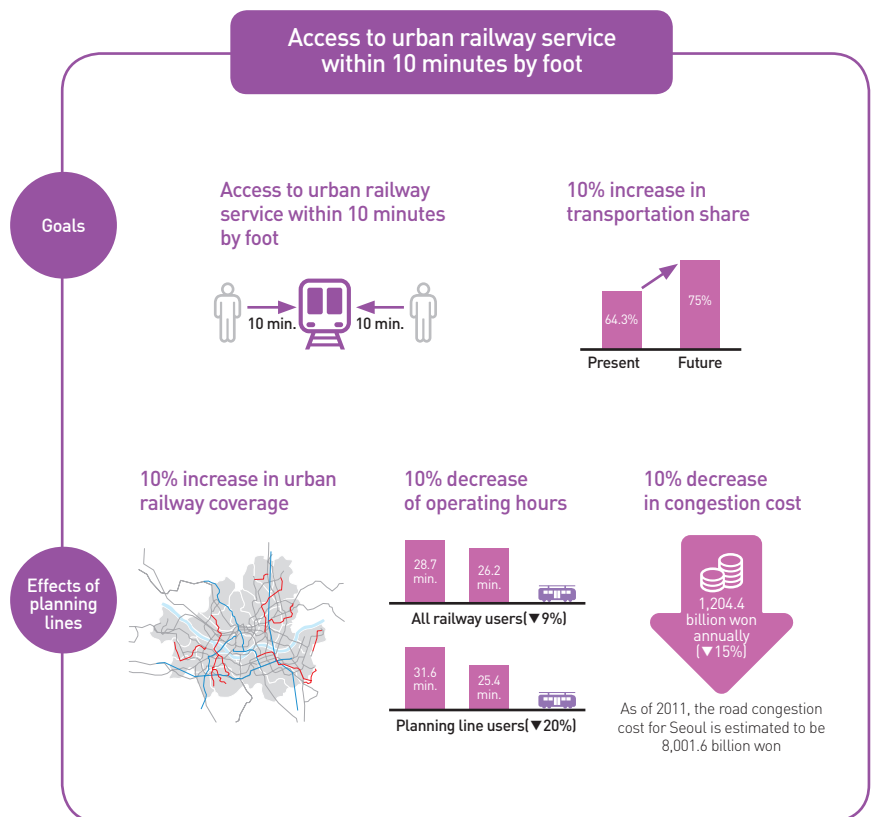

Seoul, ready to share with the world
Seoul Metropolitan Rapid Transit

Patents, Awards, and Overseas Export Expansion

Globally recognized for its cutting-edge technologies and management know-how, Seoul Metropolitan Rapid Transit is committed to sharing its best practices with cities around the world



Patents of Seoul Metro (212 patents as of 2012)

Date of application	Application no.	Title
1999-03-24	10-1999-0010055	Rail Joints Clamping Device
2002-04-16	10-2002-0020648	Rail Clamping Structure
2004-02-24	10-2004-0012205	Structure and Construction Methods of Tracks on Concrete Roads
2005-01-24	5001314	Railroad Concrete Construction and Method (foreign) and 6, et al
2006-05-04	10-2006-0040406	Subway Gate Device and its Control Methods and 2, et al
2007-01-04	10-2007-0001038	Master Control Broadcast System Testing Device and 13, et al
2008-01-16	10-2008-0005051	Per Train-Type Congestion Control System and Methods and 31, et al
2009-01-22	10-2009-0005373	Safety Footholds for Urban Railway Locomotives and 22, et al
2010-01-22	10-2010-0006033	24 items including cartridge-type bicycle holders
2011-04-06	10-2011-0031559	Reinforcement of Compounding Materials equipped with Clamping Units to Improve Seismic Performance and Sustainable Binding and 8, et al
2012-06-15	10-2012-0064037	Slope Elevator (I) and 4, et al

Patents of Seoul Metropolitan Rapid Transit Corp

Date of application	Application no.	Title
2006-07-04	10-2006-0062481	Composite Screen Door Switching Control System
2007-12-11	10-2007-0128455	Screen Door Head Box Reinforcing Structure
2004-02-24	10-2008-0039407	PSD Assembly Modules (modular PSD assembly)
2011-10-31	PCT/ KR2011/008232	Railway Facility Monitoring System and Methods using Track Vehicles

Examples of overseas expansion

1. Master design of tracks of Ho Chi Minh urban railway line 1 in Vietnam
2. Signaling system renovation consulting for 11 stations between Chitagong – Chinkiaстана, Bangladesh
3. Training seminars by inviting railway professionals overseas
4. MOU with D'Appolonia in Italy for a light rail project
5. Mutual tech cooperation agreement with 2 urban railway institutions in Brazil (Sanpaolo Metro, Rio de Janeiro Metro)



▶ MOU with Vossloh in Germany for the application of Seoul Metro's B2S method to the urban railway system in Singapore (10/30/2012)

Q&A

Q1. How did Seoul's urban railway policy develop over the years from initial planning to construction and development?

Due to rapid population increase and territorial expansion, Seoul Metropolitan Government had to resolve the challenge of growing traffic demand as a top priority. So it announced a ten-year plan for urban administration in 1965 to examine the ground extending 51.5 kilometers and among it build urban railway in a 14.8 kilometer section. Despite financial and technological difficulties, it finally began construction for Subway Line 1. Afterwards, Seoul's urban railway has continued to develop with the development of the city; today, it has grown to become a sophisticated means of transportation with the best on-time operation and the lowest accident rate in the world.

1st Generation Subway Construction (lines 1~4) [1970 ~1985]

- In the 1970s, the pace of increase of cars in Seoul was faster than that of population in Seoul. This aggravated the traffic congestions in downtown Seoul. So Seoul Metropolitan Government placed top priority on subway construction and created a Seoul Subway Construction Headquarters in June 1970. At the time, the biggest problem was how to secure the fund, which was solved through loans from foreign countries and technology partnerships with them. The construction of Subway Line 1 finally began in 1971. Later, Korean engineers participated in each phase of the project from survey, planning, design, to construction – paving the way for localization of urban railway construction technologies and serving as a catalyst for Korean construction companies to expand their businesses overseas to the Middle East in the 1980s.
- When Subway Line 2 was under construction, 20 percent of the entire population of Korea was concentrated in Seoul, the area of which accounts for merely 0.64 percent of the total area of Korea. In addition, all of the nation's key functions were concentrated in downtown Seoul, causing more serious traffic congestion and even traffic paralysis. So Seoul Metropolitan Government launched projects to build Subway Line 2 (circulating the city) and Subway Lines 3 and 4 (passing through the city from one end to another) so that the city could develop in a more balanced manner. Line 2 opened service in 1984 and Lines 3 and 4 opened services simultaneously in 1985. This was the first generation of urban railway construction in Seoul – lines 1, 2, 3, and 4 extending 118 kilometers.

2nd Generation Subway Construction (line 5~8) [1989 ~2001]

- Urban railway construction was temporarily suspended due to enormous deficit from 1st generation subway construction and too little number of passengers in the initial period. However, in the late 1980s, demand for urban railway soared, traffic congestion reached its peak, and downtown traffic problems became a major political and social issue again. So Seoul Metropolitan Government launched projects to build Subway Line 5 (connecting East and West parts of the city; opened service in 1996), Line 6 (connecting East and West parts of Gangbuk passing through World Cup Stadium, opened service in 2001), Line 7 (connecting Northeast and Southwest parts of the city, opened service in 2000), and Line 8 (built to meet traffic demand in Gangnam and satellite cities). During 2nd generation subway construction period, 4 new lines were constructed extending 145 kilometers. Also, an additional 15 kilometers were built for lines constructed during 1st generation subway construction period.

3rd Generation Private Investment (line 9) and Light-rail Transit Construction [2002~present]

Although Seoul Metropolitan Government experienced burden of debt due to excessive loans to fund 1st and 2nd generation subway construction and too low of a subway fare (because subway was a means of public transportation), there were continuous demand for better urban railway service from the citizens, driven by continuous growth and expansion of the city. Thus Seoul Metropolitan Government decided to introduce private investment projects and light-rail transit. Line 9 (opened 1st stage of service in 2009) was launched through private investment projects, which helped supplement the insufficient budgets. Currently, Seoul Metropolitan Government is planning to build 10 light-rail transit in areas in the city that have been isolated from urban railway benefits.

Q2. Many cities around the world experience various challenges in the process of constructing urban railway. What were some of Seoul's challenges and how did Seoul overcome them?

- In the mid-1950s, right after the Korean War, the Seoul population started to increase rapidly driven by the city's full-blown economic growth and accelerated urbanization, reaching over 3.0 million in the early 1960s. At this time, the city's traffic congestion issue accompanied by territorial expansion was brought to the fore as a big challenge related to the city's growth and administrative process.
- To tackle these issues, Seoul Metropolitan Government officially announced the "Subway Line 1 Construction and Metropolitan Subway Scheme" in 1970 with strong resolution. The city launched the subway line 1 construction project the following year and opened the service in 1974.
- At present, 40 years after line 1 started its service, Seoul, a global city and home to over 10.0 million citizens, has a total of 9 subway lines covering a 327.1km-long route and serving nearly 7.2 million commuters on the average every day.

Obstructions and solutions 1 Lack of financial and technological capacity ▶ Attracted foreign capital and technologies

It was not an easy decision for Seoul to go ahead with such a large project, given its difficult financial situation of having to rely on massive loans from overseas. Nonetheless, the city managed to embark on subway line 1 construction with firm resolution and strong will to resolve the urgent traffic congestion issue and proactive measures to attract foreign capital and technologies. After opening the line 1 service, the city successfully established an extensive metropolitan railway network in a short period of time including subway line 2, 3, and 4, which have grown with the history of Seoul and taken root as the most trusted public transportation for ten million Seoul citizens.

Obstructions and solutions 1 Encourage citizens to switch from their cars to public transportation.

Guided by the belief that rapid transits are not simply a means of transportation but should be a daily life space for citizens, Seoul Metropolitan Government adopted a sustainable service automation system, expanded amenities, and improved the fare plan and safety facilities to provide the world's top-class subway service.

1. Excellent on-time operation and security

- Seoul Metropolitan Rapid Transit has become a reliable means of transportation that local citizens trust the most, with its outstanding, continuous on-time operation at 99.9% all year round and efficient ordinary and express train service.
- Seoul Metropolitan Rapid Transit is fully equipped with platform screen doors and anti-disaster systems at every station, and all locomotives are made of inflammable materials.

2. Convenient access and pleasant environment

- Every station has both escalators and elevators to help disabled people use the service without inconvenience. Each station tries to control the air quality in a strict manner and offer an environment with cultural and artistic spaces existing in harmony.

3. Reasonable fare

- Passengers can travel anywhere around the country at a low price using a traffic card that levies fare based on the travel distance regardless of how many times they use public transportation service including bus and rapid transit. (Transportation cost saving of up to 510,000 won/year per citizen)
- Citizens can freely transfer between rapid transit lines and buses at a reasonable fare of 1,050 won (about \$1.0) for a distance of up to 10km without having to pay additional costs (Changes in fare (70s (30 won) → present (1,050 won) / Changes in prices reflected)

Q3. Which institutions run urban railway in Seoul?

Since the opening of line 1 in 1974, urban railway in Seoul currently extends 327 kilometers (including 290 kilometers underground) with 9 lines and approximately 2.6 billion passengers a year.

Current status of urban railway in Seoul

- 9 lines extending 327 kilometers with 302 stations
- approximately 7.2 million passengers a day
- approximately 2.6 billion passengers a year
- share of public transportation: urban railway (36.2%), bus (28.1%), car (24.1%), taxi (7.2%), other (4.4%)

Urban railway operators

Items	Public		Private
	Seoul Metro	Seoul Metropolitan Rapid Transit Corp.	Metro 9
No. of lines	4lines (1~4)	4lines (5~8)	1lines (9)
Extension	137.9km	162.2km	27km
Stations	120	157	25
No. of Passengers	4,180,000/day	2,640,000/day	380,000/day

Q4. What are some cases in which Seoul shared its advanced technologies and experiences with other cities around the world?

Seoul Metropolitan Government has 40 years' experience in introducing and running the world's top-class rapid transits, which have undergone rapid growth and accumulated a range of related technologies. It has secured technologies to meet the needs of developing countries around the globe, and it is committed to introducing new technologies and establishing innovative operation systems. Seoul Metropolitan Government has been exchanging tech and other related resource information with major cities around the world through occasional training seminars by inviting rapid transit professionals abroad who benchmark the city's related policies and practices.

Case 1 Inviting urban railway staff from abroad to participate in training program in Seoul

Since 2008, Seoul Metropolitan Government is inviting public servants working in urban railway to visit Seoul to participate in a training program. Usually around 20 people are invited and the program is held two times a year.

[Training program for urban railway staff from abroad]



Period	Scale	Coordinator
2008	8 people from a single nation(Macao)	SMRT
2008 ~ 2012	65 people from 7 countries (Vietnam, Thailand, Laos, Mongol, India, Indonesia, Bangladesh)	Seoul Metro
2013	20 people from 5 nations (Libya, Vietnam, Thailand, Indonesia, Azerbaidzhen)	Seoul City

Case 2 Consulting for overseas urban railway and business participation

For more information about Seoul Metropolitan Rapid Transit, please contact below. We will be more than happy to accommodate your requests.

For more information about Seoul Metropolitan Rapid Transit, contact us at the following, and we will do our best to serve your needs:

Contact Information

Postal Address: 231, Samil-daero, Jung-gu, Seoul, Korea, 100-731 Light Rail Task Force,
Urban Railway Bureau, Seoul Metropolitan Infrastructure Headquarters

Phone: +82-(0)2-2133-5272

Fax: +82-(0)2-774-2122

E-mail: policyshare@seoul.go.kr

Website: <http://english.seoul.go.kr/>

